



**WREN IBT SERIES
HYDRAULIC TORQUE WRENCHES
IBT SQUARE DRIVE SERIES**

OPERATION AND MAINTENANCE MANUAL

FOR WREN Products:

POINT 75, 1IBT, 3IBT, 5IBT, 8IBT, 10IBT, 20IBT, 25IBT, 35IBT, 50IBT

SQUARE DRIVE HYDRAULIC TORQUE WRENCHES

Series Point 75, 1IBT, 3IBT, 5IBT, 8IBT, 10IBT, 20IBT, 25IBT, 35IBT and 50IBT Square Drive Hydraulic Torque Wrenches are designed for installing and removing threaded fasteners requiring precise high torque during bolt makeup and maximum torque during bolt breakout.

It is necessary to read and understand this Operation and Maintenance Manual when using WREN Hydraulic Torque Wrenches. The use of other than genuine WREN replacement parts may result in safety hazards, decreased tool performance, increased maintenance and may invalidate warranty.

Read this manual carefully before operating tool.



IMPORTANT SAFETY INSTRUCTIONS

IMPORTANT INSTRUCTIONS ON RECEIPT (OPEN PACKAGE INSPECTION)

Carefully inspect all components for shipping damages. If any shipping damage is found, notify the carrier at once. Shipping damage is NOT covered by warranty. The carrier is responsible for all repair or replacement cost resulting from damage in shipment.

The hydraulic torque wrench is a power tool. Read all the instructions, warnings and cautions before every operation. Comply with the safety precautions to avoid personal injury or equipment damage while operating this tool! Neither WREN, nor its distributors are responsible for damage to the tool caused by unsafe and/or faulty operations.

SAFETY FIRST!

▲ WARNING

To avoid personal injuries and/or equipment damage, be sure that every hydraulic component of the hydraulic torque wrench, hydraulic hose assembly, hydraulic power pack and gauge are rated for 10,000 PSI (700kg/cm²) operating pressure.

▲ WARNING

To minimize the danger of injury and damage to equipment: Never use a hydraulic torque wrench without a hydraulic gauge to indicate the working pressure. The hydraulic gauge is a window to show what is happening in the hydraulic system.

▶ DO NOT exceed the allowable maximum torque of the hydraulic torque wrench.

▲ WARNING

Immediately replace any worn or damaged parts of the tool with genuine WREN replacement parts.

▲ CAUTION

All of the hydraulic torque wrench components of the tool are kept away from excessive heat, flame, moving machine parts, sharp edges and chemicals.

▲ CAUTION

Reduce damage to the hydraulic hose assembly by avoiding sharp bends and kinks when routing the hydraulic hose assembly. Using a bent or kinked hydraulic hose assembly will cause severe back-pressure. Also, sharp bends and kinks will internally damage the hose leading to premature failure. A kinked or damaged hydraulic hose assembly should be replaced immediately.

▲ CAUTION

DO NOT drop heavy objects, crush, or drive over the hydraulic hose assembly. A sharp impact may cause internal damage to the hose wire strands. Applying pressure to a damaged hose may cause it to rupture. A crushed hydraulic hose assembly should be replaced immediately.

▲ CAUTION

Avoid high temperature exposure to the hydraulic hose assembly.

▶ ALWAYS INSPECT THE HYDRAULIC HOSE ASSEMBLY FOR DAMAGE AND WEAR PRIOR TO USE.

▲ WARNING

To avoid personal injuries, equipment damage and/or warranty invalidation:

- **DO NOT:**
 - Remove the shroud from the hydraulic torque wrench.
 - Modify any component of the hydraulic torque wrench.
 - Adjust the hydraulic torque wrench safety relief valve located inside the swivel couplings.

▲ CAUTION

The incorrect system connection may cause failure and injury. Before connecting the hydraulic torque wrench and hydraulic hose assembly to the assembled power pack, make sure the hydraulic torque wrench swivel couplings, hose couplings and hydraulic power pack couplings are clean and free of debris.

▶ LOOSE OR DIRTY COUPLERS WILL CAUSE TOOL NOT TO OPERATE PROPERLY.

▲ CAUTION

DO NOT use old or damaged sockets.

DO NOT use the wrong size sockets.

▲ WARNING

Only use a high quality socket. The socket must measure up to standard ISO-2725 and ISO-1174 or DIN3129 and DIN3121 or ASME-B107.2/1995. Never use a chrome plated socket.

▲ WARNING

Always use a pin to lock the socket with the square drive in order to avoid the socket from falling off.

PROPER SAFETY ATTIRE

When operating hydraulic equipment, use proper safety equipment and clothing. Consult with your company's safety representative to obtain this information.

OPERATION SECTION

Reference

The Operation and Maintenance Manual of the electric or air powered hydraulic power pack.

Hydraulic Torque Wrench Set Up

Connect the *IBT* square drive hydraulic torque wrench and hydraulic power pack with the proper twin line hydraulic hose assembly making sure all connections are proper and snug. If the couplings are not properly mated the hydraulic torque wrench may not operate.

Preparation

1. Make certain of the size of the nut or bolt head, material, strength grade and determine the desired torque.

Appendix I, which is presented as a guideline for comparison only, gives typical torque values specified for the most commonly encountered fasteners. Torque sequence may vary from manufacturer to manufacturer and even within individual factories, depending on the gasket material etc.

► **Always abide by the manufacturers/engineers procedures.**

2. Determine the torque value needed and then determine the corresponding pressure of the torque wrench pump. This can be found in the Pressure - Torque Conversion Chart that was provided with the hydraulic torque wrench. You may also find this chart on the web @ **www.wrentools.com**
3. Inspect the hydraulic torque wrench set. Connect the hydraulic torque wrench, hydraulic hose assembly and the hydraulic power pack in to a hydraulic circuit. Ensure that all hydraulic connections are securely connected. Verify that the hydraulic hose assembly is not kinked, crushed or damaged.

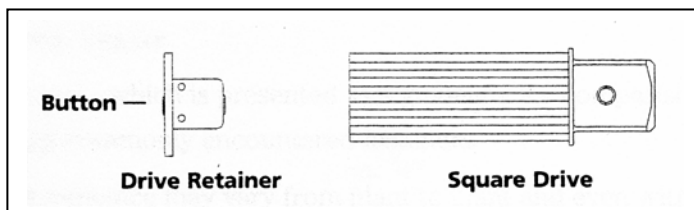

4. Setting the Square Drive for Rotation:

The position of the square drive when looking at the shroud will determine if the hydraulic torque wrench is set to loosen or tighten. When the square drive extends to the **LEFT** when looking at the shroud, the hydraulic torque wrench is set to **loosen**. When the square drive extends to the **RIGHT**, the hydraulic torque wrench is set to **tighten**.

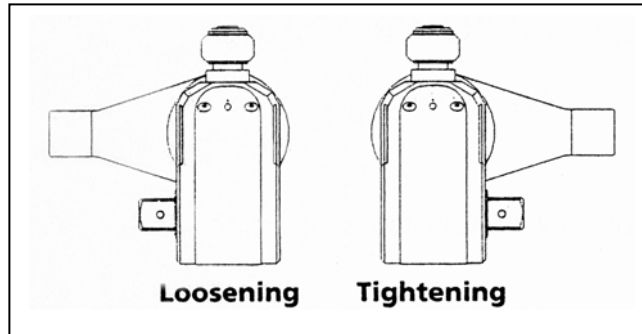

LEFT IS LOOSE.

RIGHT IS TIGHT.

To remove the square drive: Disengage the drive retainer assembly by depressing the center round button and gently pulling on the square end of the square drive. The square drive will then slide out.

To insert the drive in the hydraulic torque wrench: Place the drive in the desired direction, engage drive and bushing splines. Then, twist the drive and bushing until the ratchet spline can be engaged. Push the drive through the ratchet. Depress drive retainer button, engage retainer with drive and release button to lock.

5. Connecting the hydraulic torque wrench:

The hydraulic torque wrench and torque wrench power pack are connected by a 10,000 PSI operation pressure twin line hydraulic hose assembly.

IMPORTANT

To avoid hydraulic torque wrench malfunction:

► **DO NOT reverse connectors.**

DO NOT tamper with the set screw on the swivel assembly. (It is factory preset for safety purposes and adjustments should only be made by trained personnel.)

Connect the hydraulic hose assembly to the swivel as shown below:

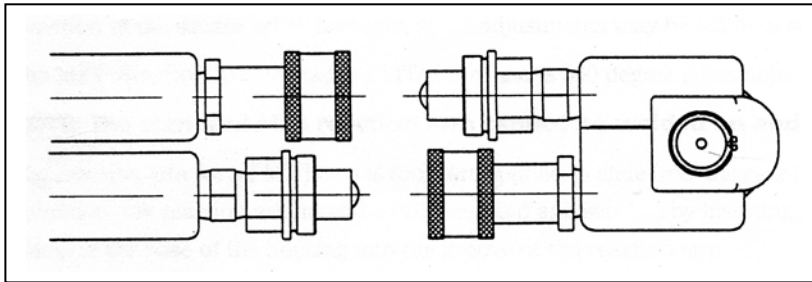

Insure the connectors are fully engaged and screwed snugly together.

Coupler Placement

Tool	Advance Side-Male Retract Side-Female
Hose	Advance Side-Female to Female Retract Side-Male to Male
Pump	Advance Side-Male Retract Side-Female

6. Setting the pressure on the hydraulic power pack:

To set the pressure on the pump, follow this procedure:

- a) Loosen the locking ring below the “T” handle on the hydraulic power pack’s external pressure regulator. Then, turn the “T” handle counterclockwise until it turns freely and easily.
- b) Turn the hydraulic power pack on. Using the hydraulic power pack remote pendant, push the advance switch (or button on the air hydraulic power pack) and hold it.
- c) While holding the hydraulic power pack in the advance mode, slowly turn the “T” handle clockwise and observe the hydraulic power pack pressure gauge rise.

Note: Always adjust the regulator pressure UP - never down.

- d) When your gauge reaches the predetermined pressure, stop turning the “T” handle and let the gauge settle.
- e) If the pressure continues to rise above the predetermined pressure, release the back pressure slightly by turning the “T” handle counterclockwise. Then, depress the advance switch on the remote and slowly bring pressure up to the predetermined pressure.
- f) When the pressure is correct, turn the pump off and tighten the locking ring which is under the “T” handle. This sets the pump pressure, which determines torque wrench output.
- g) Once your target pressure is set and locked, cycle the hydraulic power pack once more to ensure that your pressure setting did not change as you tightened the locking ring.

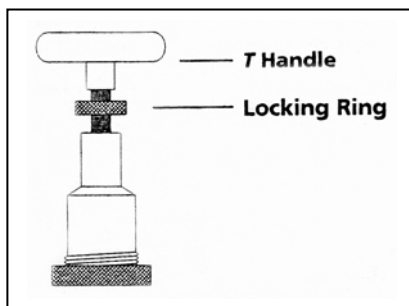

Operation

Before every operation, always read and follow the *Operation Instructions*.

The Tightening Process:

Applying the Hydraulic Torque Wrench

1. Having set your target pressure, cycle the hydraulic torque wrench three or four times to full pressure. Cycling the wrench ensures that the system is operating properly.
2. Place the proper size impact socket on the square drive and secure properly with a locking ring and a pin.
3. Place the hydraulic torque wrench and socket on the nut, making sure that the socket has fully engaged the nut. Further ensure that the drive retainer is engaged.
4. Make sure the reaction arm is firmly abutted against a stationary object (i.e. an adjacent nut, flange, equipment housing, etc.)
5. When positioning the hydraulic torque wrench, make sure the hydraulic hose assembly is clear of any obstructions and all **body parts are safely out of harm's way. This tool has massive power and can cause bodily damage.**
6. Then, and only then, apply momentary pressure to the system to ensure proper wrench placement. If it does not look or act right, stop and adjust the reaction arm.

Operating the Hydraulic Torque Wrench

1. By pushing the remote control advance button, the rear of the hydraulic torque wrench will be pushed back until the reaction arm will make contact with the reaction point.
2. Continue to hold the advance button as the socket turns until you hear an audible “click” which will signify the hydraulic cylinder inside the hydraulic torque wrench is fully extended and will not turn the socket further. Release button.
3. Continuing to hold the remote control advance button, will result in a rapid buildup of pressure to the point where the gauge reads what the hydraulic power pack was preset to prior to applying the hydraulic torque wrench.

IMPORTANT: The reading of full preset pressure after the cylinder is extended DOES NOT INDICATE that this pressure (torque) is applied to the bolt/nut. It only indicates that the cylinder is fully extended and cannot turn the socket further, until the tool automatically resets itself.

4. Releasing the remote control button will automatically retract the cylinder. The hydraulic torque wrench will automatically reset itself and the operator will hear an audible “click” indicating he can again push the remote control button and the socket will turn. Each time the cylinder is extended and retracted, it is called a cycle. Successive cycles are made until the tool “**stalls**” at the preset Torque/PSI with an accuracy of +/-3%. Repeatability is +/-1%.

IMPORTANT: ALWAYS ATTEMPT ONE FINAL CYCLE TO INSURE THE “STALL” POINT HAS BEEN REACHED.

“Locked-On”

Should the hydraulic torque wrench be “locked-on” after the final cycle, push down the remote control advance button once more (to build pressure) and while maintaining this pressure, pull back on the accuracy assurance pawl lever (located on the side of the tool). Release the remote control advance button, while continuing to push down on the accuracy assurance lever (this will allow the hydraulic torque wrench to be removed easily).

The Loosening Process:

1. Set the pump to 10,000 PSI. Change the drive to the loosening mode, assuring the reaction arm abuts squarely on a solid reaction point.
2. Press and hold the remote control advance button. Pressure will decrease as the socket begins to turn. As the cylinder extends fully, you will hear an audible “click”.
3. Release the remote control advance button and the cylinder automatically retracts, at which time you again hear the audible “click”.
4. Repeat this process until the fastener can be removed by hand.

NOTE: IF THE BOLT/NUT DOES NOT LOOSEN WITH THE ABOVE PROCEDURES, IT IS AN INDICATION THAT YOU REQUIRE A LARGER HYDRAULIC TORQUE WRENCH TO LOOSEN THE BOLT/NUT.

After the operation

1. Upon completing the project; turn off the power to the hydraulic power pack.
2. Disconnect all the coupler connections between the hydraulic torque wrench and hose, and then the hose and hydraulic power pack.

3. Loosen the locking ring below the “T” handle on the hydraulic power pack external pressure regulator. Then, turn the “T” handle counterclockwise until it turns freely and easily.
4. When not in use, tools and accessories should be properly stored to avoid damage.

MAINTENANCE SECTION

Preventative Maintenance

- **Lubrication**

All moving parts should be periodically coated with a good quality lubricant. Under harsh environmental conditions, cleaning and lubricating should be performed more frequently.

- **Hydraulic Hose Assembly**

The hydraulic hose assembly should be inspected for cracks, burns, kinks, crush spots and leaks after each job. Hydraulic fittings can become plugged with dirt and should be flushed periodically. If any damage to the hydraulic hose assembly is found, the hydraulic hose assembly should be replaced immediately.

- **Connectors**

Hydraulic coupler fittings should be kept clean and not allowed to be dragged on the ground or floor. Even small particles of dirt can cause the internal valves to malfunction.

- **Springs**

Springs are used for the drive pawl assembly and the accuracy assurance pawl. These springs can be replaced if necessary.

▪ **Cylinder Seals**

If the cylinder requires disassembly, it is recommended that the cylinder seals be replaced at the same time. Seal kits are readily available.

▪ **Structural Members**

All structural parts on the tool should be inspected periodically to determine if there are any cracks, chips or deformities. If so, immediate replacement is required.

▪ **Calibration**

Calibration should be performed at least once a year on all hydraulic torque wrenches and gauges.

TROUBLE-SHOOTING CHART

SYSTEM	PROBABLE CAUSE	REMEDY
Cylinder will not advance	<ol style="list-style-type: none"> 1. Coupler loose or damaged 2. Dirt in direction-control valve on pumping unit 3. Coupler not mated securely. 	<ol style="list-style-type: none"> 1. Tighten/Replace 2. Disassemble and clean 3. Tighten
Cylinder will not retract	See above	See above
Cylinder will not build up pressure	<ol style="list-style-type: none"> 1. Piston seal leak 2. Coupling is not mated properly or is defective 3. Gauge 	<ol style="list-style-type: none"> 1. Replace seals 2. Replace coupling 3. Replace gauge
Cylinder leaks	Safety release valve on cylinder	Replace cylinder seals
Cylinder operates backwards	Disconnects are reversed on hoses, pump, or tool	Reverse disconnects on tool
Ratchet returns on retract stroke	<ol style="list-style-type: none"> 1. Broken reaction pawl 2. Defective reaction pawl spring 	<ol style="list-style-type: none"> 1. Replace 2. Replace
Ratchet will not make successive strokes	<ol style="list-style-type: none"> 1. Defective drive pawl spring 2. Defective drive pawl 3. Cylinder is not retracting completely 	<ol style="list-style-type: none"> 1. Replace 2. Remove tool from job, cycle freely once or twice, and return to job
Tool cannot be removed from nut	Reaction pawl is engaged	Begin forward cylinder stroke. While applying pressure, pull back reaction pawl release lever (on side of tool). While holding release, allow the cylinder to retract. Remove tool

IBT

No pressure reading on gauge	<ol style="list-style-type: none"> 1. Gauge not tight 2. Pump coupling broken 3. Gauge defective 4. Defective cylinder seals 	<ol style="list-style-type: none"> 1. Tighten coupler 2. Replace 3. Replace 4. Inspect and replace all cylinder seals
Pump will not build pressure	<ol style="list-style-type: none"> 1. Defective relief valve 2. Air supply too low or air hose size too small 3. Electric power source is too low 4. Gauge 5. Filter is clogged 	<ol style="list-style-type: none"> 1. Inspect and replace 2. Check for 100 PSI air pressure, 1" ID air hose 3. Insure suitable electric power source – 25amps – 12 gauge or larger extension cord 4. Replace 5. Inspect and clean, or replace
Pressure reading erratic	Defective gauge	Replace

Disassembly

1. Make sure the hydraulic cylinder is fully retracted.
2. Remove the reaction arm (#18).
3. Remove shroud (#44) by removing the four buttonhead cap screws (#45) at top and base of the housing.
4. Remove square drive (#32) by pressing center button of drive retainer (#33.1) while pulling square drive out of tool.
5. Remove the two drive sleeve circlips (#31). Remove the drive sleeve spline (#30).
6. Remove the two housing plugs (#21) to uncover housing access holes.
7. Line up rod pin (#34) with access holes in housing and punch rod pin through housing.
8. Remove ratchet (#42), two drive plates (#43) and drive pawl assembly (#38).

IBT

9. Remove the screw from each release lever (#26 & #28) and pull the release levers out of housing.
10. Remove the reaction pawl (#25), along with the reaction pawl spring (#23).
11. Remove the end cap (#14.1).
12. Remove the piston rod assembly. Consists of (#7.1, 8, 9, 10.1, 11, 12 and 13).
13. To change the seals, refer to the exploded view drawing.

Note: Refer to the exploded view drawing. For assembly, follow the instructions in reverse.

Appendix I***Recommended Torque For B7 Studs (ASTM A193)******Based Upon 50% Yield***

Bolt diameter	Heavy hex nut size (A.F.)	Lubricated torque using copper, graphite or comparable lubricant with a coefficient of friction F-.100 (both nut face and threads should be well lubricated)	Dry steel on steel, no lubricant, coefficient of friction F-.400
3/4"	1-1/4"	157	559
7/8"	1-7/16"	250	893
1"	1-5/8"	373	1332
1-1/8"	1-13/16"	538	1994
1-1/4"	2"	746	2720
1-3/8"	2-3/16"	1000	3678
1-1/2"	2-3/8"	1307	4837
1-5/8"	2-9/16"	1682	6260
1-3/4"	2-3/4"	2109	7888
1-7/8"	2-15/16"	2602	9775
2"	3-1/8"	3167	11942
2-1/8"	3-5/16"	3809	14408
2-1/4"	3-1/2"	4531	17191
2-3/8"	3-11/16"	5339	20310
2-1/2"	3-7/8"	6238	23786
2-3/4"	4-1/4"	7533	28846
3"	4-5/8"	9803	37670
3-1/4"	5"	12488	48129
3-1/2"	5-3/8"	15622	60365
3-3/4"	5-3/4"	19241	74516
4"	6-1/8"	22162	86146
4-1/4"	6-1/2"	23337	90720
4-1/2"	6-7/8"	26332	102513
4-3/4"	7-1/4"	30994	120831
5"	7-5/8"	36176	141210

IBT

IBT EXPLODED VIEW DRAWING

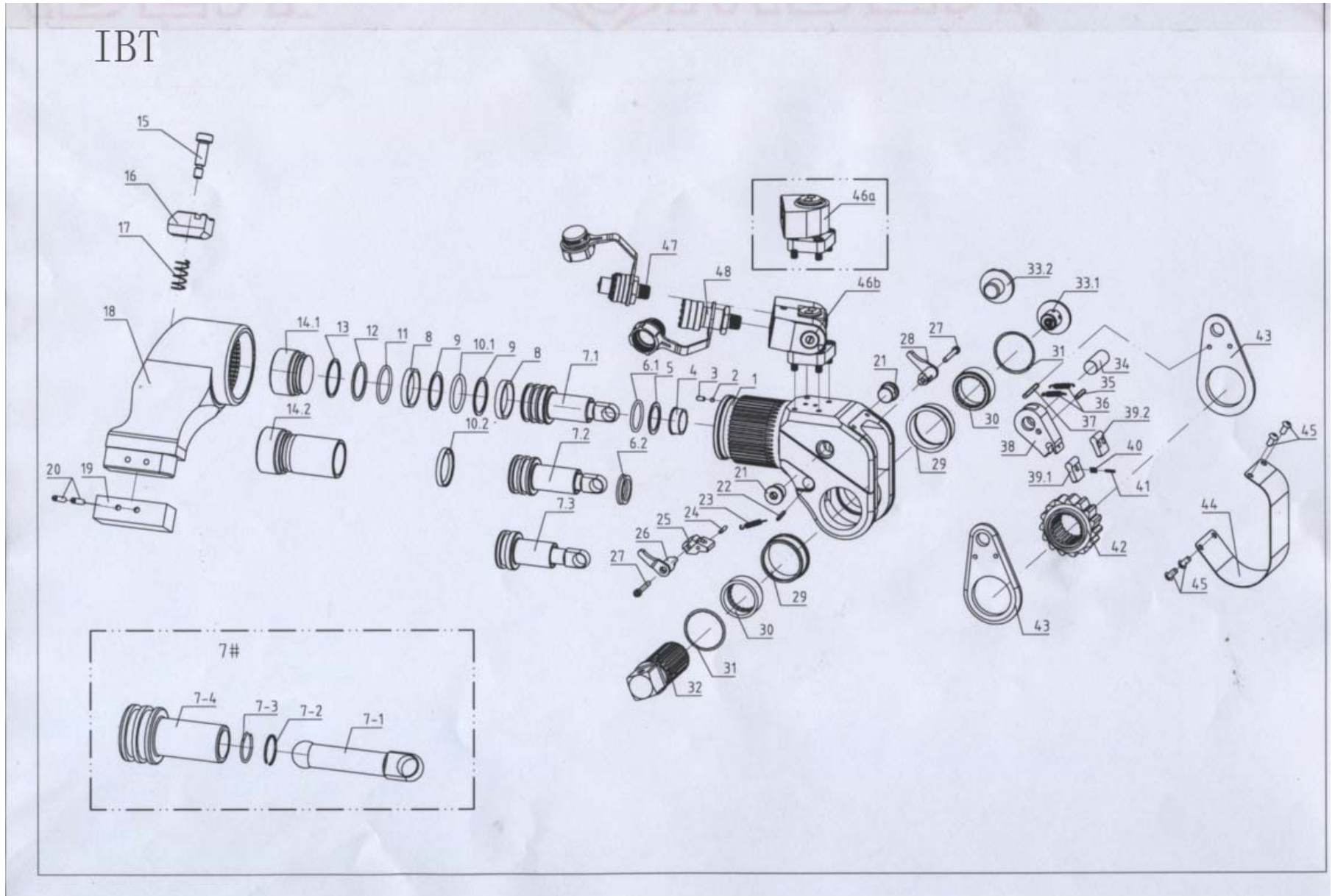

IBT

IBT SPEC SHEET

2009.02.16

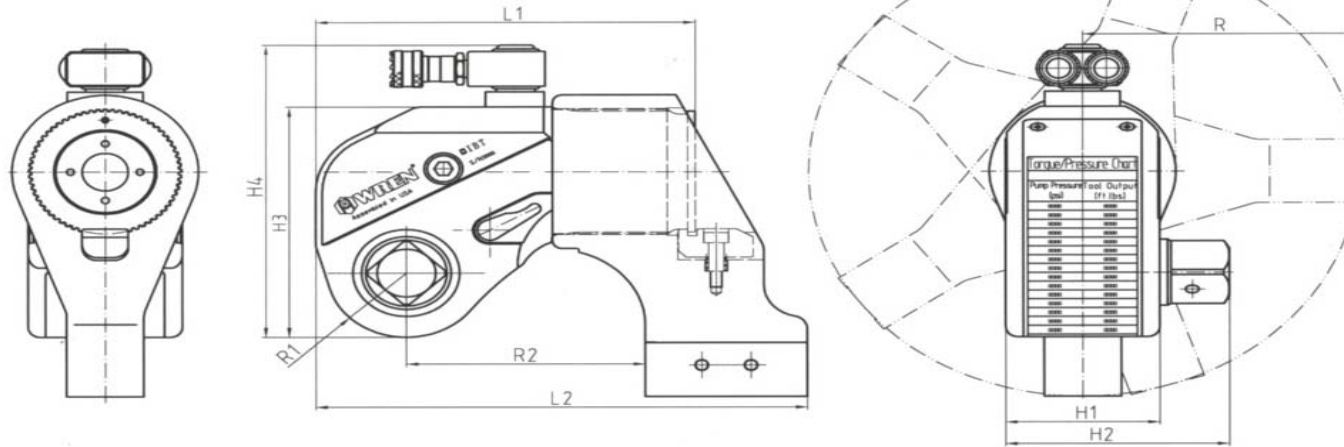

Model	<u>.75</u>	<u>1</u>	<u>3</u>	<u>5</u>	<u>8</u>	<u>10</u>	<u>20</u>	<u>25</u>	<u>35</u>	<u>50</u>
Torque (Ft-lbs)	82 ~ 826	135 ~ 1355	332 ~ 3328	555 ~ 5552	795 ~ 7950	1144 ~ 11,444	1966 ~ 19,667	2561 ~ 25,611	3589 ~ 35,894	5310 ~ 53100
Weight	4 lbs.	5.5 lbs.	11 lbs.	17 lbs.	24 lbs.	33 lbs.	58 lbs.	77 lbs.	110 lbs.	191 lbs.
Drive	3/4"	3/4"	1"	1.5"	1.5"	1.5"	2.5"	2.5"	2.5"	2.5"
L1	4.4	5.74	7.07	8.36	8.81	9.74	12.21	12.82	14.79	15.88
L2	5.53	6.89	9.09	10.74	11.63	12.6	15.22	15.92	18.48	20.49
H1	1.67	1.99	2.7	3.18	3.57	3.97	4.76	5.44	6.07	6.35
H2	2.61	2.86	3.77	4.88	5.32	5.64	7.27	7.94	8.58	8.85
H3	3.03	3.81	5.04	5.92	6.63	7.23	8.73	9.81	11.2	11.55
H4	4.29	5.2	6.99	7.9	8.61	9.21	10.72	11.79	13.18	13.54
R	2.98	3.63	4.9	5.56	6.55	7.07	8.46	9.05	9.67	10.24
R1	0.81	1.03	1.35	1.55	1.87	2.02	2.34	2.62	3.06	3.22
R2	2.71	3.37	0.04	5.44	6.07	6.11	7.38	7.9	9.57	10.28

IBT

IBT DRAWING BREAKDOWN

Drawing Number	Description
1	Housing
1A	Housing Assembly Includes drawing numbers 1 & 3
2	Steel Ball
3	Socket Head Set Screw
4	Not Applicable
5	Retaining Ring
6	Cup Seal
7.2	Piston Rod Assembly Includes drawing numbers 7-1, 7-2, 7-3 & 7-4
7-1	Piston Connected Rod
7-2	Retaining Clip
7-3	Steel Retaining Ring
7-4	Piston Rod
8	Wearable Ring
9	Retaining Ring
10	O-Ring
12	O-Ring
13	Retaining Ring
14	End Cap
15	Reaction Arm Retaining Clip Screw
16	Reaction Arm Retaining Clip
17	Reaction Arm Retaining Clip Spring
18	Reaction Arm
18A	Reaction Arm Assembly Includes drawing numbers 15, 16, 17, 18, 19 & 20
19	Reaction Arm Boot
20	Reaction Arm Boot Pin
21	Plug for Housing
22	Pin for Reaction Pawl
23	Tension Spring for Reaction Pawl
24	Pin for Reaction Pawl
25	Reaction Pawl
26	Release Lever - Left
27	Release Lever Screw
28	Release Lever - Right
29	Drive Bushing
30	Drive Sleeve Spline
20	Reaction Arm Boot Pin
21	Plug for Housing
22	Pin for Reaction Pawl
23	Tension Spring for Reaction Pawl
24	Pin for Reaction Pawl
25	Reaction Pawl

IBT

Drawing Number	Description
26	Release Lever - Left
27	Release Lever Screw
28	Release Lever - Right
29	Drive Bushing
30	Drive Sleeve Spline
31	Retaining Clip (Circlip)
32	Square Drive
33	Drive Retainer
34	Rod End Pin
35	Pin for Drive Pawl
36	Spring for Drive Pawl (need 2) Tension
37	Pin for Drive Plate
38	Drive Pawl, Primary
38A	Drive Pawl Assembly Includes drawing numbers 35, 36, 37, 38, 39 & 40
39	Drive Pawl, Secondary
40	Spring For Drive Pawl (need 2) Compression
41	Pin for Drive Pawl - Mating
42	Ratchet Spline
43	Drive Plate (need 2)
44	Shroud
45	Shroud Screw
46	Swivel Assembly, No Fittings
47	Male Coupler
48	Female Coupler